

ENMET Corporation
PO Box 979
Ann Arbor, MI 48106-0979

CO-GUARD
Compressed Air Line CO Monitor
Manual

Manual Part Number
80002-044
MCN-381, 10/17/07

Table of Contents

1.0 INTRODUCTION	1
1.1 UNPACK.....	1
1.2 CHECK ORDER	1
1.3 SERIAL NUMBERS.....	1
2.0 COMPONENTS OF THE CO-GUARD	2
2.1 CO-GUARD ELEMENTS	2
2.2 CO-GUARD OPERATIONAL FEATURES.....	2
2.3 CIRCUIT BOARD FEATURES.....	4
3.0 INSTALLATION	5
3.1 MOUNTING CO-GUARD.....	5
3.2 WIRING THE CO-GUARD	6
3.2.1 Air Supply.....	6
3.2.2 Power Supply.....	6
3.2.3 Relay Contacts.....	7
4.0 OPERATION	8
4.1 START UP CO-GUARD.....	8
4.1.1 Typical Start Up.....	8
4.2 NORMAL DISPLAY MODE	9
4.2.1 Alarm Conditions CO-GUARD	9
5.0 MAINTENANCE	10
5.1 MAINTENANCE MENUS.....	10
5.2 CALIBRATION OF THE CO-GUARD.....	12
5.2.1 Exit Maintenance Menu	13
5.2.2 Zero Adjust.....	13
5.2.3 Gas Span	14
5.2.4 Alarm Set Points	15
5.2.5 Span Set.....	15
5.4 SENSOR REPLACEMENT	16
6.0 REPLACEMENT PARTS	17
7.0 TECHNICAL DATA AND SPECIFICATIONS	17
8.0 WARRANTY	18

List of Tables

TABLE 1 : RELAY FAILSAFE SETTINGS	7
TABLE 2: FACTORY ALARM SET POINTS	9
TABLE 3: CO-GUARD MAINTENANCE MENUS SEQUENCE	10
TABLE 4: CALIBRATION GAS	13

List of Illustrations

FIGURE 1: EXTERNAL CO-GUARD FEATURES	3
FIGURE 1A: OPTIONAL REGULATOR AND SAMPLE AIR HOSE	3
FIGURE 2: CO-GUARD CIRCUIT BOARD FEATURES	4
FIGURE 3: MOUNTING CO-GUARD	5
FIGURE 4: POWER TERMINAL CONNECTIONS CO-GUARD	6
FIGURE 5: RELAY TERMINAL CONNECTIONS CO-GUARD	7
FIGURE 6: CO-GUARD MAINTENANCE MENU FLOW CHART	11
FIGURE 7: CALIBRATION ADAPTER	12
FIGURE 8: CO-GUARD SENSOR REPLACEMENT	16

Reference Information:

NOTE: [important information about use of instrument]

CAUTION: [affects equipment – if not followed may cause damage to instrument, sensor etc...]

WARNING: [affects personnel safety – if not followed may cause bodily injury or death.]



Earth Ground

1.0 Introduction

The **CO-GUARD** is a compressed air monitoring instrument that measures and detects Carbon Monoxide (CO) in industrial compressed breathing air systems utilizing an electrochemical sensor. The **CO-GUARD** is *NOT* in an enclosure rated for use in a Class I, Div 1, Groups B, C, D classified area and *CAN NOT* be installed in a hazardous location.

Features of the **CO-GUARD**:

- continuous monitoring of the sample air
- continuous LCD display of gas and vapor concentrations
- menu driven operational and maintenance controls
- menu driven calibration procedure
- audio and visual alarms indicate unsafe conditions
- alarm relay contacts available on terminals
- a fault relay and visual fault alarm
- air flow indicator, flowmeter
- alarm acknowledgement capability including audio defeat
- mA outputs for target gas

NOTE: *All specifications stated in this manual may change without notice.*

1.1 Unpack

Unpack the **CO-GUARD** and examine it for shipping damage. If such damage is observed, notify both **ENMET** customer service personnel and the commercial carrier involved immediately.

Regarding Damaged Shipments

NOTE: It is your responsibility to follow these instructions. If they are not followed, the carrier will not honor any claims for damage.

- This shipment was carefully inspected, verified and properly packaged at our company and delivered to the carrier in good condition.
- When it was picked up by the carrier at **ENMET**, it legally became your company's property.
- If your shipment arrives damaged:
 - Keep the items, packing material, and carton "As Is." Within 5 days of receipt, notify the carrier's local office and request immediate inspection of the carton and the contents.
 - After the inspection and after you have received written acknowledgment of the damage from the carrier, contact **ENMET** Customer Service for return authorization and further instructions. Have your Purchase Order and Sales Order numbers available.
- ENMET** either repairs or replaces damaged equipment and invoices the carrier to the extent of the liability coverage, usually \$100.00. Repair or replacement charges above that value are your company's responsibility.
- The shipping company may offer optional insurance coverage. **ENMET** only insures shipments with the shipping company when asked to do so in writing by our customer. If you need your shipments insured, please forward a written request to **ENMET** Customer Service.

Regarding Shortages

If there are any shortages or questions regarding this shipment, please notify **ENMET** Customer Service within 5 days of receipt at the following address:

ENMET Corporation
680 Fairfield Court
Ann Arbor, MI 48108
734-761-1270 734-761-3220 Fax

1.2 Check Order

Check the contents of the shipment against the purchase order. Verify that the **CO-GUARD** is received as ordered. Each **CO-GUARD** is labeled with its target gas. If there are accessories on the order, ascertain that they are present. Check the contents of calibration kits. Notify **ENMET** customer service personnel of any discrepancy immediately.

1.3 Serial Numbers

Each **CO-GUARD** is serialized. These numbers are on tags on the equipment and are on record in an **ENMET** database.

2.0 Components of the CO-GUARD

2.1 CO-GUARD elements

See Figure 1 for location of elements:

Feature	Description
Enclosure	A polycarbonate box, approximately 7 x 5 x 3, with a detachable front cover. 4 holes for mounting the enclosure to a vertical surface. Located at the corners of the bottom of the enclosure, directly beneath the 4 front cover retaining screws. See Figure 3
Input Port	The entrance for the air sample and calibration gas. The quick release fitting mates with one on the optional Sample air hose and the calibration adapter.
Front Cover	Detachabale front cover of CO-GUARD with Display Panel. See Section 2.2 and Figure 1 There are 4 Screws that hold the front cover in place.
Sample Air Hose (Optional)	A five foot long hose to conduct a sample of the air from the source to the instrument. The hose has a Female quick release fitting and regulator. See Figure 1a
Regulator (Optional)	To connect to the compressed air line. Sample pressure to the CO-GUARD should be set to 55 PSI. See Figure 1a

2.2 CO-GUARD Operational Features

The Display Panel is attached by a cable and is released by unscrewing the 4 screws located in the corners. After releasing the panel, it is swung upward, exposing the interior of the enclosure. See **Figure 1** for location of features.

Feature	Description
Display	A single line, 8 character LCD with backlight. Indicates the level of gas detected by sensor. The numerical value of gas concentration and other information is displayed.
Audio Alarm(Horn)	Audio alarm (105 dB at 30cm/12in). The audio alarm is on when the unit is in alarm.
Visual Indicators and Alarms	LED indicators: Power / Fault Indicator LED, Green / Red Alarm (3) Indicator LED, Red
Membrane Switches	2 Pushbutton Switches on front panel control the instrument maintenance functions. The pushbutton switch locations are indicated by: MENU ↓: Advances the instrument display through operation information and maintenance menus SELECT →: Disables audio alarm temporarily and Selects the maintenance menu operations such as, Zero, Span, Exit menu or sets proper calibration values for Zero or Span See Section 4.0 and 5.0 for operational and maintenance flow charts.
Flowmeter	A flow indicator located at the output of the sample flow stream, which indicates quantitatively the flow of sample air or calibration gas through the instrument.

Three alarm points are preprogrammed into the **CO-GUARD**. At each alarm point, an LED on the front panel is activated. These internal alarm settings are independent of the 4-20mA output alarm values that can be set at a controller. An optional relay board is available that will activate 0.5 Amp relay contacts at each alarm point, plus a fault relay.

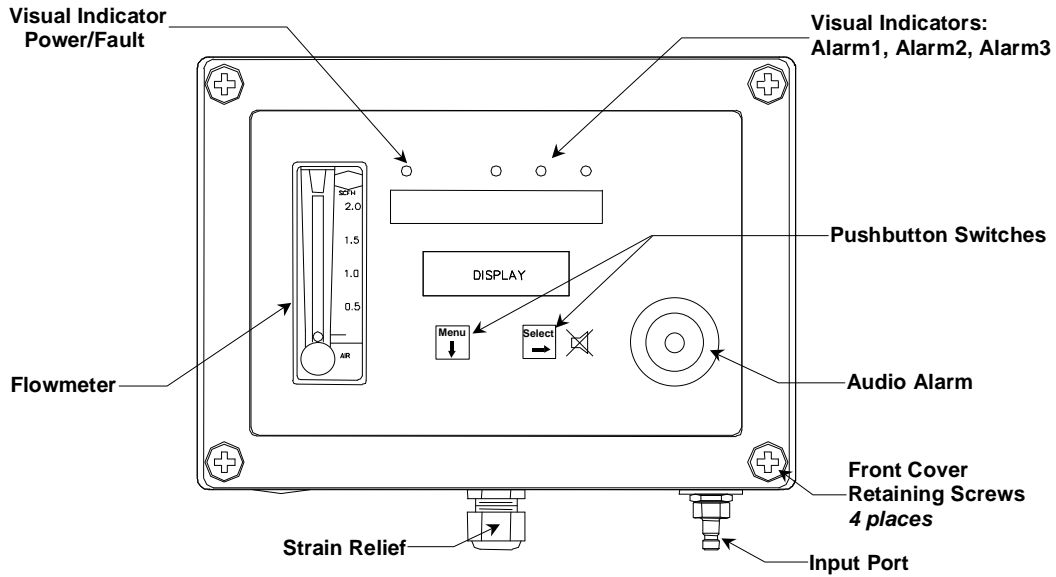

Figure 1: External CO-GUARD Features

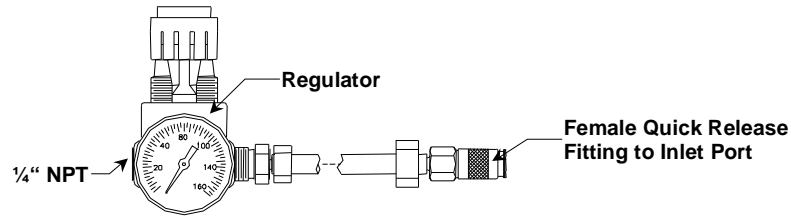

Figure 1a: *Optional* REGULATOR AND SAMPLE AIR HOSE

2.3 Circuit Board Features

The Display Panel is attached by a cable and is released by unscrewing the 4 screws located in the corners. After releasing the panel, it is swung upward, exposing the interior of the enclosure. The Circuit Board is mounted at the back surface of the enclosure interior. Features are shown in **Figure 2**.

Feature	Description
Relay Terminals	This group of terminals is located on the Circuit Board. For the contacts for each of three alarm relays, and for the contacts of a fault relay. See Section 3.2.3
Output Terminals	For the 4-20 mA output.
PCB/Sensor Manifold	The PCB/Sensor manifold. The carbon monoxide sensor located under this housing.

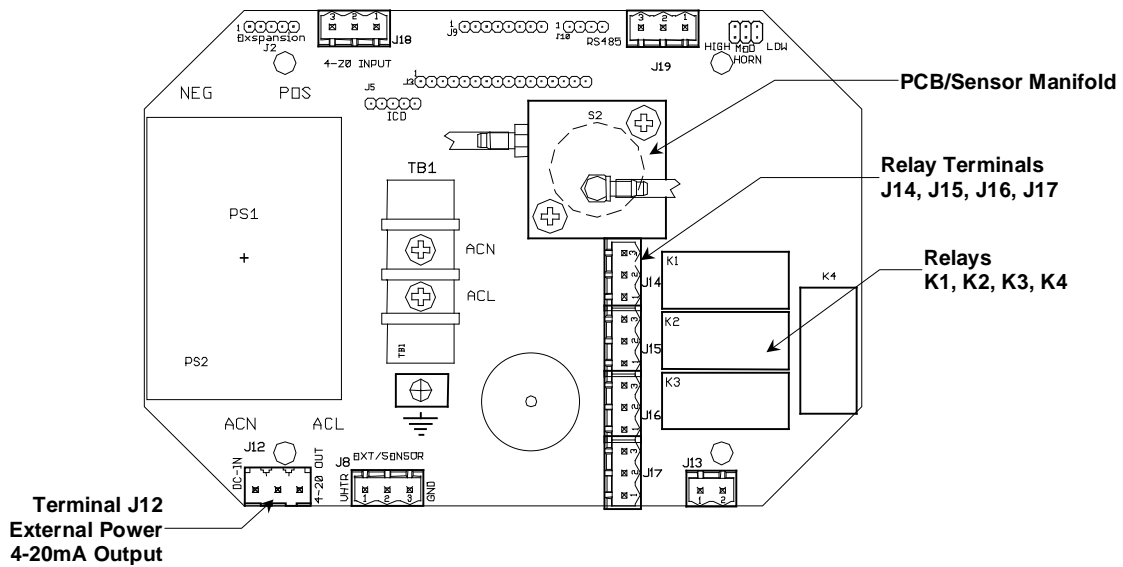

Figure 2: CO-GUARD Circuit Board Features

3.0 Installation

The **CO-GUARD** should be located near the pipe or tank containing the air to be monitored, and upstream from where the air is being used. The **CO-GUARD** must be installed such that it samples the compressed air before it reaches the users.

3.1 Mounting CO-GUARD

Mount the **CO-GUARD** instrument on an appropriate vertical surface, leaving room for lid to be opened, using the mounting holes provided. Avoid areas with excessive vibration or temperature extremes. The holes in the bottom of the enclosure are 0.18 inch in diameter and form a 6.44" x 4.47" rectangle. **See Figure 3**

It is recommended to use #8 drywall anchors and screws for mounting the **CO-GUARD** to a drywall/sheetrock surface.

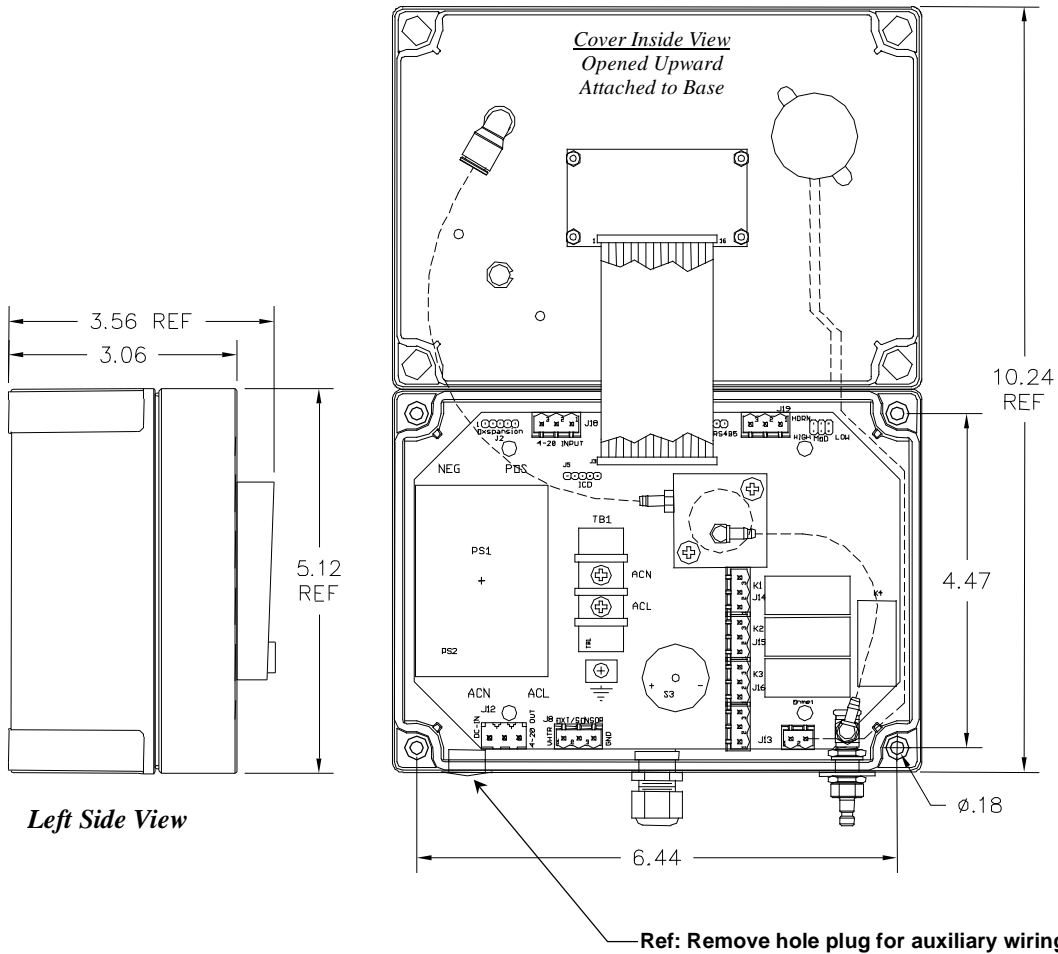

Dimensions are in inches.

Figure 3: Mounting CO-GUARD

3.2 Wiring the CO-GUARD

The electrical installation should conform to appropriate electrical codes, such as the National Electrical Code in the United States.

WARNING: The compliance of the installation to appropriate codes is not **ENMET's** responsibility.

The **CO-GUARD** should be powered through circuit breakers provided for this purpose.

3.2.1 Air Supply

Tap the pipe or tank containing the breathing air and use appropriate fittings to connect the sample input hose. The instrument is designed to operate from an air supply pressure 55 PSIG. The sample input hose length should be as short as possible.

The **CO-GUARD** should be tapped into the compressed air line upstream of all respirator connection points to ensure the **CO-GUARD** monitors the supplied air *Before* it gets to the respirator connection points.

3.2.2 Power Supply

The input power can vary from 100 to 240 VAC, 50/60 Hz. Power should be connected to the Power Input Terminal **TB1** and the *Ground screw*. See **Figure 4** for location.

WARNING: Continuous gas detection and alarm systems (110VAC/220VAC / 24VDC/12VDC powered) become inoperative upon loss of primary power. Contact factory for specifications and pricing of backup battery systems.



Upon supplying air and power to the **CO-GUARD**:

- The green power on LED is lit.
- The display backlight is lit, and instrument will step through a start-up sequence: unit serial number and software revision may be shown on the display.

The instrument may go into alarm briefly, but the sensors stabilize quickly. If the instrument persists in alarm, acknowledge the alarm by pressing the **SELECT** button. If alarm persists longer than 30 minutes, call **ENMET** customer service personnel.

For DC wiring 24Vdc may be wired to J12, (J12-1)position 1 + with ground connected to (J12-2)position 2.

AC Power Supply Terminal: TB1

	Label on PCB	Function
110VAC	TB1 ACN	Neutral
	TB1 ACL	Line
Ground Screw		AC GND
220VAC <i>Optional</i>	TB1 ACN	Neutral
	TB1 ACL	Line
Ground Screw		AC GND

DC Power Supply Terminal: J12

Position	Function
1 +	24 VDC power
2	GND
3	4 - 20 mA out

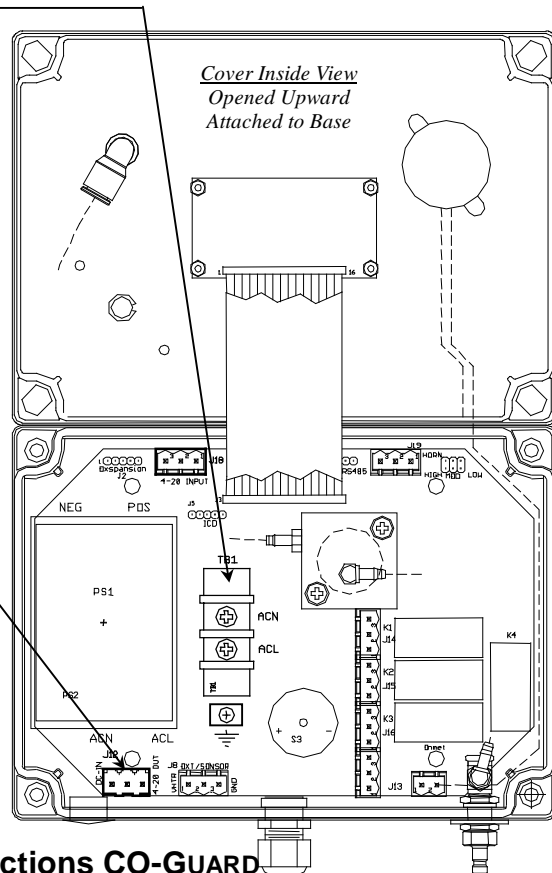

Figure 4: Power Terminal Connections CO-GUARD

3.2.3 Relay Contacts

Relay contacts are available for each alarm; these are SPDT, rated at 10Amp at 110VAC, and may be latching or non-latching as required by the application.

They are accessed on the terminals next to each relay see **Figure 5**. The contact positions are noted on the circuit board next to each terminal.

The following table is for the relays in their un-energized state. This is also the alarm condition state. Non-failsafe configured relays in the alarm state, are the reverse of the PC board labeling. Note that the Fault(FLT) relay cannot be set to operate in a Non-Failsafe mode. Please see **Table 1**

Table 1 : Relay Failsafe Settings

Alarm	Position	
Alarm 1	J14 (K1)Relay 1 - NO	Normally Open
	J14 (K1)Relay 1 - NC	Normally Closed
	J14 (K1)Relay 1 - COM	Common
Alarm 2	J15 (K2)Relay 2 - NO	Normally Open
	J15 (K2)Relay 2 - NC	Normally Closed
	J15 (K2)Relay 2 - COM	Common
Alarm 3	J16 (K3)Relay 3 - NO	Normally Open
	J16 (K3)Relay 3 - NC	Normally Closed
	J16 (K3)Relay 3 - COM	Common
Fault Alarm	J17 (K4)Relay 4 - NO	Normally Open
	J17 (K4)Relay 4 - NC	Normally Closed
	J17 (K4)Relay 4 - COM	Common

These relay contacts can be used to operate auxiliary alarms or other functions. Auxiliary alarms should be powered from an independent power source separate from the instrument power to avoid alarm failure due to controller malfunction. Use the existing hole in the enclosure for a wire exit, and use appropriate cable fittings. See **Figure 2**. Be sure to note the location and depth of hardware inside the enclosure.

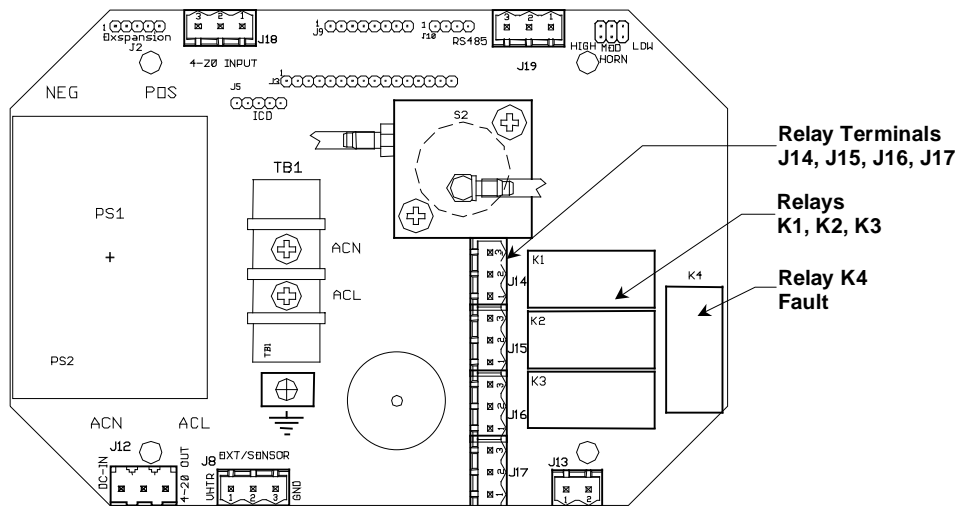

Figure 5: Relay Terminal Connections CO-GUARD

4.0 Operation

When the **CO-GUARD** is installed as described in **Section 3**, and in clean air, the **POWER** green LED is on, the display is lit and the information on the display is measurement of carbon monoxide detected by the **CO-GUARD**. The red alarm and fault LEDs are not lit.





4.1 Start Up CO-GUARD

When the **CO-GUARD** is first powered up, it goes through a series of momentary screens, which identify the instrument model number, serial number and software revision. After all of the momentary screens have been displayed, the instrument arrives at the Main Gas Display showing the gas concentration and unit of measurement.

Depending on transmitter configuration and calibration condition, the furthest right character in the display may flash a letter indicating the instrument status. See the Section 4.1.1 below

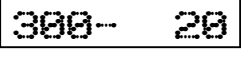
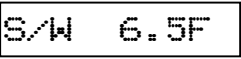
4.1.1 Typical Start Up

When power is supplied to the **CO-GUARD**, the instrument will display the following sequence of information:
Typical start up sequence of information displayed.

Example of Typical Start Up Display	Function
	The instrument: Model CO-GUARD
	The instrument: Serial Number
	The instrument: Software Revision
IF the right most character is a flashing W 	The instrument is in Warm-up mode <ul style="list-style-type: none"> This should last about 1 minute The Signal Output is held at 4mA during warm-up
IF the right most character is a flashing C 	The instrument has failed Calibration The last good calibration values are retained, but the sensor may not be responsive to gas A new Calibration should be performed <i>As Soon As Possible</i>
	The instrument: Normal Display Mode Measurement of Carbon Monoxide

NOTE: Software revision may cause variations of display output.

4.2 Normal Display Mode

When the **CO-GUARD** is installed as described in section 3, and in clean air, the **POWER** green LED is on, the display is lit and the information on the display is measurement of carbon monoxide detected by the **CO-GUARD**. The red alarm and fault LEDs are not lit.

To advance through displays of operational information press the **MENU** button.

See sequence of operational information below:

Display Measurement of CO
Press **MENU** button

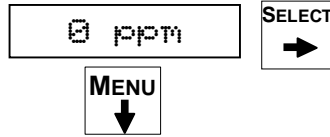

To temporarily disable audio alarm, see **Section 4.2.1**

Display indicates Alarm 1 Set point
Press **MENU** button

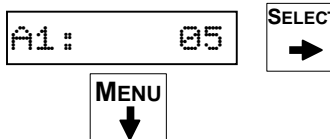

To temporarily disable audio alarm, see **Section 4.2.1**

Display indicates Alarm 2 Set point
Press **MENU** button

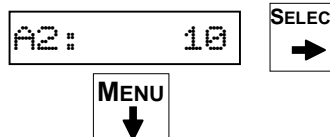

To temporarily disable audio alarm, see **Section 4.2.1**

Display indicates Alarm 3 Set point
Press **MENU** button

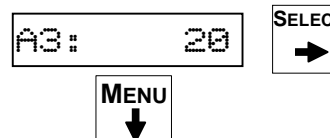

To temporarily disable audio alarm, see **Section 4.2.1**

Display indicates mA Span range (Full Scale)
Press **MENU** button

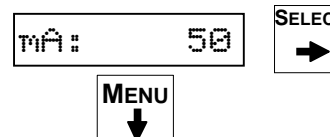

To temporarily disable audio alarm, see **Section 4.2.1**

Display returns to CO measurement

Operational Display Flow Chart

4.2.1 Alarm Conditions CO-GUARD

There are three alarm set points for CO. The factory settings of these alarm set points are shown in **Table 2**.

Table 2: Factory Alarm Set Points

Gas	Alarm 1	Alarm 2	Alarm 3
Carbon Monoxide	5 ppm	10 ppm	20 ppm

These alarm set points can be changed within limits; see the maintenance section of this manual for the procedure.

If the CO concentration increases above that of the alarm set point, the associated red LED is lit, the associated relay changes state, and the audio alarm is activated.

Pressing the **SELECT** button can temporarily disable the Audio Alarm. The horn will be disabled for about five minutes. If a second alarm condition occurs during this time the horn will re-activate. If the alarm condition(s) have ended during this time the horn will not re-activate.

5.0 Maintenance

The **CO-GUARD** maintenance menus that are accessed by pressing the **MENU** button and entering a valid access code. The access code is set at the factory and may be changed by following the access code menu explained in section 5.5.

5.1 Maintenance Menus

CAUTION: Do Not Attempt A Span Procedure Without Calibration Gas Applied to The Sensor; if this is done, the instrument is forced into a calibration fault mode.

Pushbutton switches control the **MENU** and **SELECT** functions. The **MENU** and **SELECT** button locations are indicated on the display panel, see **Figure 3**. The **MENU** button is used to display the various menu options and make incremental changes to numbers such as alarm points, calibrations gas, etc. The **SELECT** button is used to select that option, set zero or span digit.

To enter the maintenance menu press and hold the **MENU** button for 2 to 4 seconds

Table 3 indicates the maintenance menu sequence see **Figure 6** for a detailed maintenance menu flow chart.

Table 3: CO-GUARD Maintenance Menus Sequence

Example of Display	Function
<div style="border: 1px solid black; padding: 5px; display: inline-block;">5ppm</div> Normal Display Mode	Measurement of CO
Press and <i>hold</i> the MENU button for 2 – 4 seconds to enter the Maintenance Menu The Power/Fault LED will flash Green – Red to indicate the CO-GUARD is in Maintenance Mode	
<div style="border: 1px solid black; padding: 5px; display: inline-block;">Exit</div>	To exit the maintenance Menu and return to the Normal Display Mode: If intended function Press SELECT button
Press the MENU button to advance to the Zero procedure	
<div style="border: 1px solid black; padding: 5px; display: inline-block;">Zero</div>	For adjusting Zero: If intended function Press SELECT button
Press the MENU button to advance to the Span procedure	
<div style="border: 1px solid black; padding: 5px; display: inline-block;">Span</div>	For adjusting the Span: If intended function Press SELECT button
Press the MENU button to advance to each Alarm set point procedures	
<div style="display: flex; flex-direction: column; align-items: center;"> <div style="border: 1px solid black; padding: 5px; margin-bottom: 5px;">Alarm1</div> <div style="border: 1px solid black; padding: 5px; margin-bottom: 5px;">Alarm2</div> <div style="border: 1px solid black; padding: 5px;">Alarm3</div> </div>	For adjusting the Alarm 1, 2 and 3 set points: If Intended function Press SELECT button
Press the MENU button to advance the mA Span set point procedure	
<div style="border: 1px solid black; padding: 5px; display: inline-block;">mA Span</div>	For adjusting the mA Span set point: If intended function Press SELECT button

Pressing the **MENU** button without pressing the **SELECT** button will allow you to cycle through the menu options. You must Press the **SELECT** button in order to initiate the desired operation.

Normal Gas Display

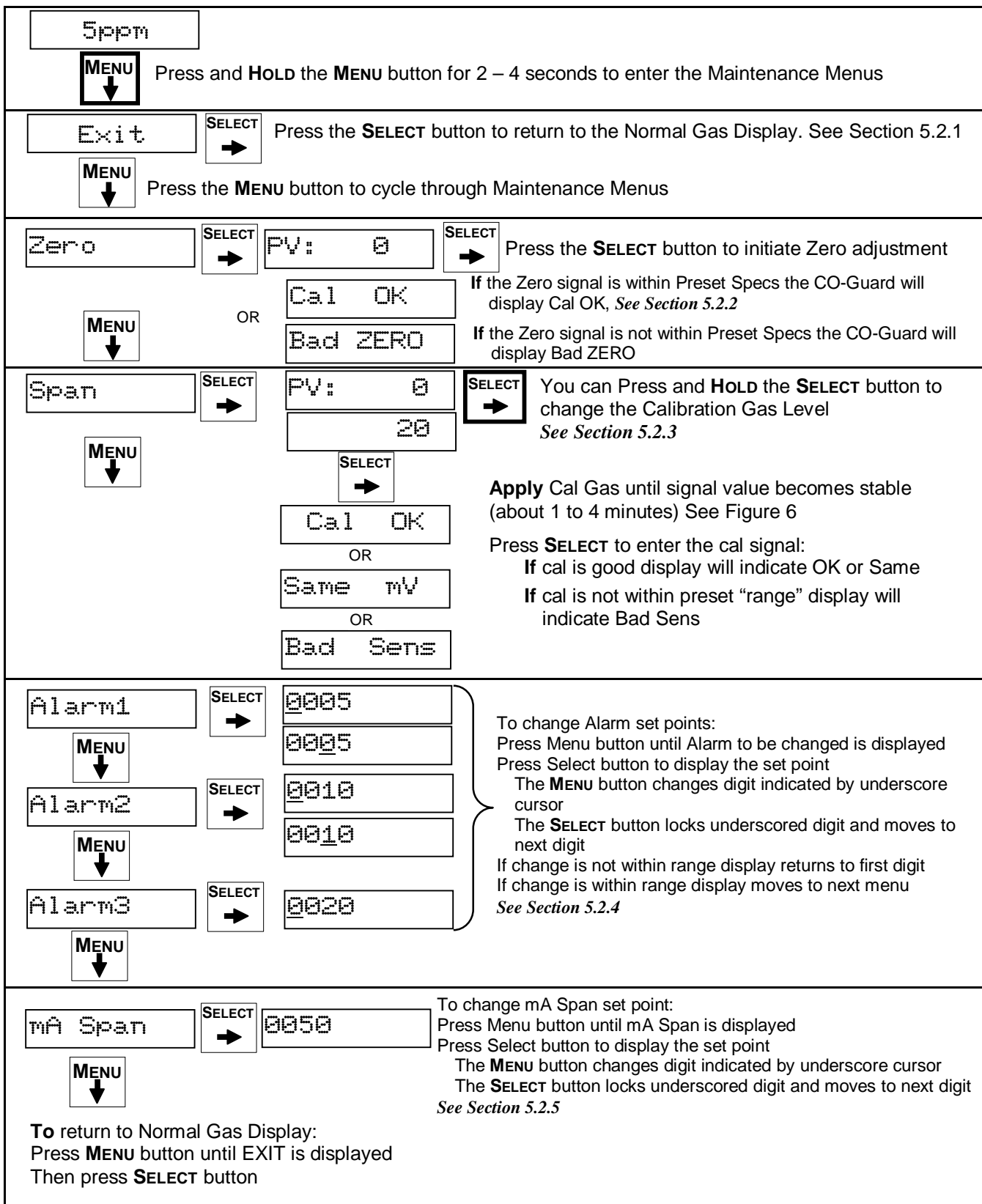

FIGURE 6: CO-GUARD Maintenance Menu Flow Chart

5.2 Calibration of the CO-GUARD

Calibration is the process of setting the instrument up to read accurately when exposed to a carbon monoxide gas. The Zero function sets the clean air reference point and the Span function sets the sensitivity of the instrument.

Initial Calibration: Wait 3 – 4 hours after initially supplying power to the **CO-GUARD** instrument before initial calibration. The **CO-GUARD** has been precalibrated at the factory, and initial field calibration should result in only fine tuning to circuit, as well as a way to check that installation is successful. It is not necessary to open the enclosure to make adjustment. The calibration functions are operated with pushbuttons from outside the enclosure through the **MENU** and **SELECT** switches.

Calibration Zero and Span functions are two separate procedures. They operate independently of each other. It is recommended that the Zero procedure be done prior to the Span procedure.

*ENMET Corporation recommends at least quarterly calibration of the **CO-GUARD** instrument.*

Calibration equipment is available from **ENMET** Corporation to calibrate the **CO-GUARD** instrument.

- Calibration adapter, a length of tubing with a regulator for the gas cylinder on one end, and a quick release fitting to connect to the sample input of the **CO-GUARD** on the other.
- Gas cylinder, Zero gas 20.9% oxygen or Span gas, typical 20 ppm CO
- Aerosol cylinder, contains Zero gas or Span gas. Supplied with flow regulator bellows assembly.
- Adapter aerosol cylinder, with quick release fitting to connect to the sample input of the **CO-GUARD**.

Generally, a cylinder of 20.9% Oxygen is used to provide a Zero point or fresh air reference for the calibration.

A cylinder of Carbon Monoxide is used to provide the Span reference point for calibration. 20ppm CO is recommended.

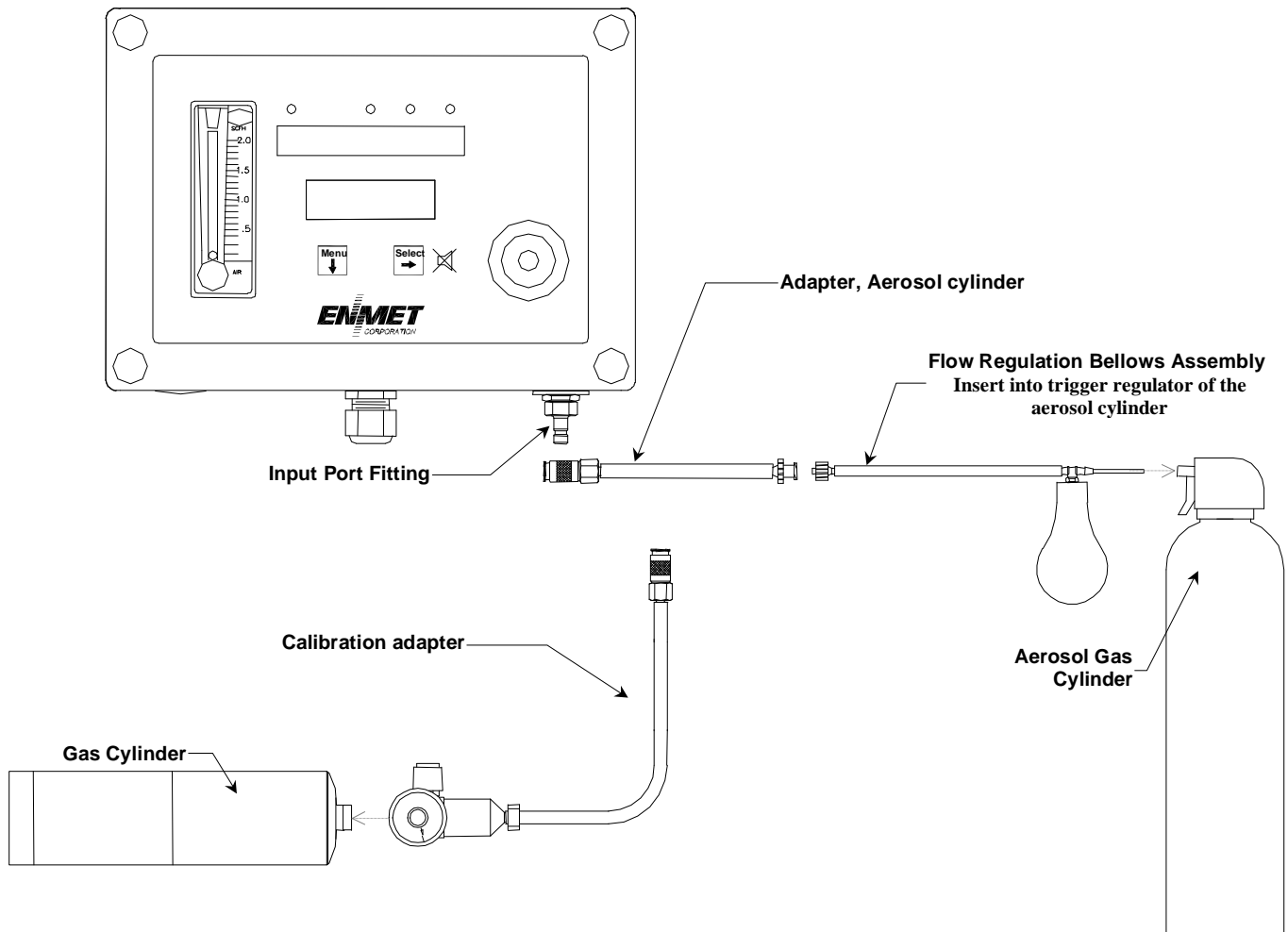

Figure 7: Calibration Adapter

Table 4: Calibration Gas

Gas	Range	Alarm 1	Alarm 2	Alarm 3	Sensor Part Number	Span Calibration Gas
Carbon Monoxide	0 – 50 PPM	5 PPM	10 PPM	20 PPM	67025-1200	20 PPM Carbon Monoxide

5.2.1 Exit Maintenance Menu

Exit maintenance, by pressing the Exit appears on the display. Press the **SELECT** button to return to the instrument Normal Gas Display.

Example of Exit menu:

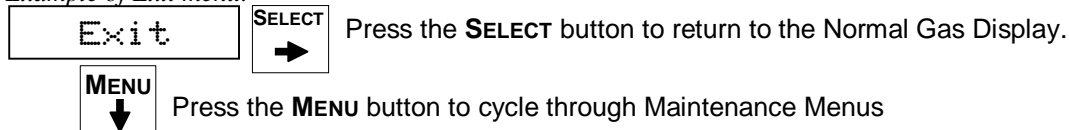

5.2.2 Zero Adjust

The ZERO function must be performed by exposing the **CO-GUARD** instrument to clean fresh air. If the air at the sensor is in question, use a cylinder of 20.9% oxygen to provide a clean air reference.

Enter the maintenance menu by pressing and holding **MENU** button for 2 to 4 seconds. See **Figure 6, CO-GUARD** Maintenance Menu flow chart.

After entering the maintenance menu, Press the **MENU** button until the Zero menu is displayed.

Press the **SELECT** button to perform a Zero.

The display will alternate between Zero and PV: To abort Zero function press and hold **MENU** button for 3 – 4 seconds, Abort? will appear, press **SELECT** button to return to Zero.

Press the **SELECT** button to initiate a Zero adjustment.

An auto detect sequence is initiated. After 15 seconds, the **CO-GUARD** will monitor the zero reading for stability.

- *If the reading stabilizes*, within the pre-programmed perimeters, an automatic zero adjustment will be made. Cal OK appears on the display and in 1 – 2 seconds, display will change to Span. If you wish to Span the sensor press the **SELECT** button you are now ready to apply gas. **Proceed to gas span step 2**
If you wish to Exit the maintenance menu, press **MENU** button until Exit is displayed, then press **SELECT** button to return to the instrument Normal Gas Display
- *If the reading does not stabilize*, within 255 seconds, the procedure will be aborted. Sensor is outside of safe parameters to be zeroed, the display will read Bad Zero. Repeat Section 5.2.2 Zero Adjust making sure to use a Zero gas of 20.9% Oxygen. **ENMET** part number 03296-209 or 03100-209.

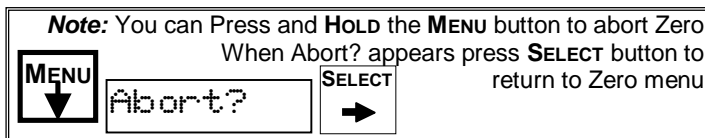

Example of Zero adjustment display:

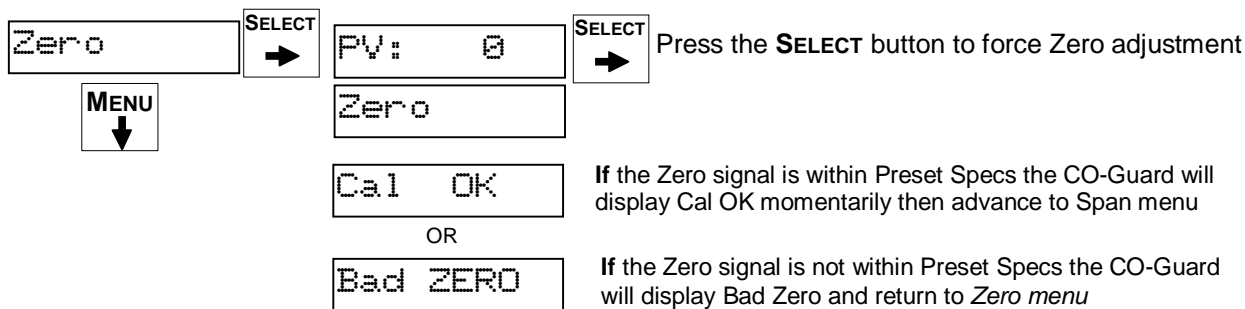

5.2.3 Gas Span

It is recommended that the Zero Function be performed first.

Do not perform a calibration unless span gas is applied to sensor. Calibration can be aborted by pressing and holding the **MENU** button for 3 – 4 seconds.

Enter the maintenance menu. See **Figure 6, CO-GUARD Maintenance Menu** flow chart.

1. Press the **MENU** button until Span display.
2. Press the **SELECT** button to perform a Span procedure.
 The display will alternate between the calibration gas concentration (Cal 20) and a signal level (PV).
 To Abort calibration press and Hold **MENU** button for 3 – 4 seconds, Abort? will appear, press **SELECT** button to return to Span.
 To change calibration gas level to be used, press and Hold **SELECT** button for 3 – 4 seconds, use menu button to change digit and select button to move to next digit.
3. Attach the associated aerosol gas or calibration gas cylinder to the calibration adapter. See **Figure 6** on calibration adapter.
4. Open the valve or pull the trigger to expand the bellows, to apply the calibration gas to the sensor.
 An auto detect sequence is initiated after 30 seconds, the **CO-GUARD** will monitor the cal reading for stability.
5. Watch for the signal level to stabilize. 1 – 4 minutes.
6. Once the signal level has stabilized,
 - If the Span is successful, Cal OK appears momentarily, then will advance to Alarm1 menu.
 - If the sensor is outside of acceptable parameters, Bad Span is displayed.
 - If the sensor did not respond, an incompatible span gas was applied and the sensor did not respond at all, Same mV is displayed then will return to Span.
 → If calibration is not successful, it is suggested that calibration be attempted again in 30-60 minutes.
 If the sensor will not calibrate See Section 5.4.
7. Remove the calibration gas.
8. Calibration is complete.
 Note: The instrument will return to operation mode in 3 – 5 seconds.
9. Press the **MENU** button to advance to next desired menu

NOTE: To abort calibration or change calibration gas level.

You can Press and **HOLD** the **MENU** button to abort Calibration
 When Abort? appears press **SELECT** button to advance to Alarm1 menu

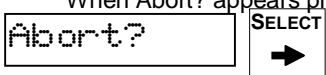

You can Press and **HOLD** the **SELECT** button to change the Calibration Gas Level
 -Use the **MENU** button to change digits 20
 -Use the **SELECT** button to move to next digit

Example of Calibration Display:

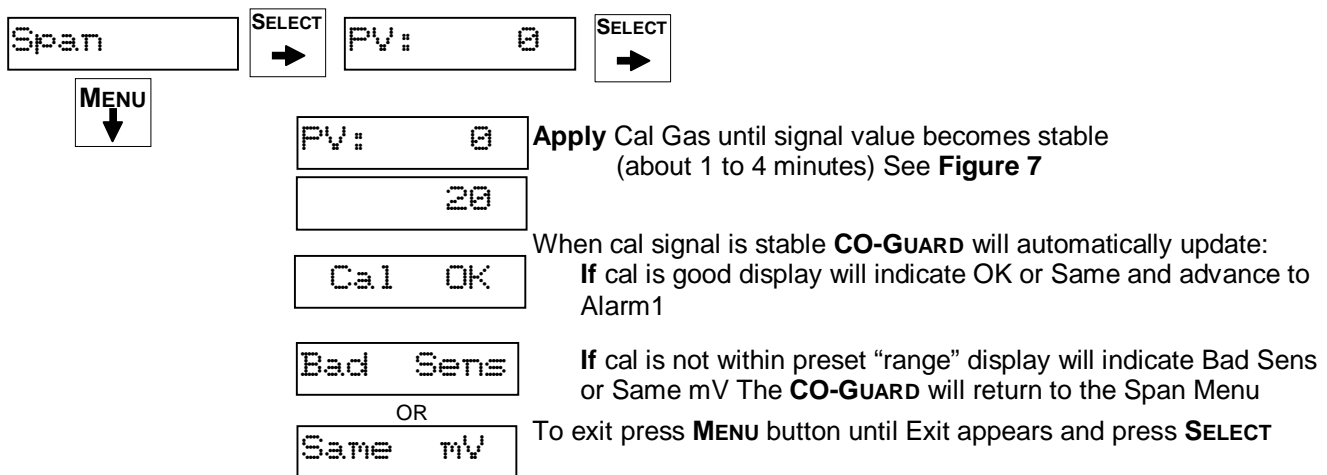

Span [SELECT] → **PV: 0** [SELECT] → **Cal 20** [MENU] ↓ **Cal OK** OR **Bad Sens** OR **Same mV**

Apply Cal Gas until signal value becomes stable (about 1 to 4 minutes) See **Figure 7**

When cal signal is stable **CO-GUARD** will automatically update:
 If cal is good display will indicate OK or Same and advance to Alarm1
 If cal is not within preset “range” display will indicate Bad Sens or Same mV The **CO-GUARD** will return to the Span Menu
 To exit press **MENU** button until Exit appears and press **SELECT**

5.2.4 Alarm Set Points

The **CO-GUARD** alarm set points can be changed within limits. See **Table 4** for factory set alarm points.

To change any of the three alarm points:

Enter the maintenance menu as shown in **Figure 6 CO-GUARD Maintenance Menu** flow chart.

1. Press the **MENU** button until to display Alarm1 is displayed.
2. Press the **SELECT** button to initiate alarm set point change
3. Press the **MENU** button to change the digit indicated by the underscore cursor
4. Press the **SELECT** button to move the cursor to the next digit
When last digit is entered the **CO-GUARD** will advance to the next menu
5. Press the **MENU** button to advance to the next menu

Example of Alarm Set Point menus:

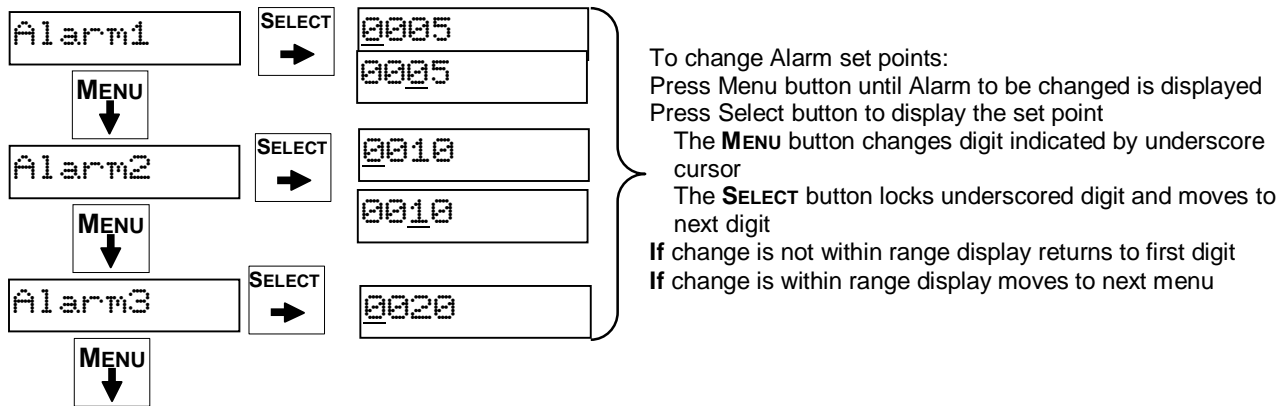

5.2.5 Span Set

The **CO-GUARD** 4-20mA span range can be changed within limits. See **Table 4** for factory set range.

To change the span range:

Enter the maintenance menu as shown in **Figure 6 CO-GUARD Maintenance Menu** flow chart.

1. Press the **MENU** button until to display Span is displayed.
2. Press the **SELECT** button to initiate the mA Span menu
3. Press the **MENU** button to change the digit indicated by the underscore cursor
4. Press the **SELECT** button to move the cursor to the next digit
When last digit is entered the **CO-GUARD** will advance to the next menu
5. Press the **MENU** button to advance to the next menu

Example of mA Span menu:

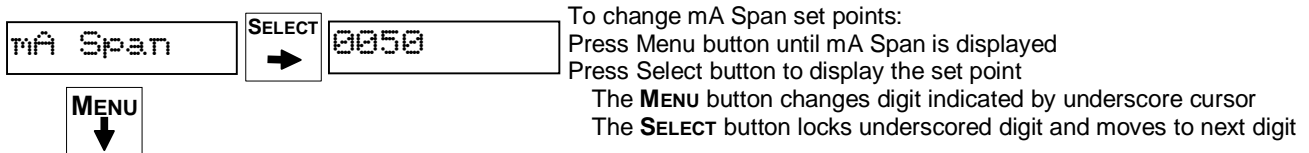

Default mA Span

4mA	20mA
0 ppm	50 ppm

5.4 Sensor Replacement

WARNING: Power must be removed from the CO-GUARD before this or any internal procedure. Failure to do so may cause damage to equipment, bodily injury or death.

Sensors should be replaced when they can no longer be calibrated. Replacement sensor part numbers are listed in **Section 6.0** of this manual. If you do not know the proper part number for your sensor, have the **CO-GUARD** serial number available when contacting your Distributor or **ENMET** Corporation Technical Support.

- Remove, the 4 retaining screws from **CO-GUARD** lid and 2 retaining screws form sensor manifold, see Figure 6
- Remove, the sensor assembly from the PCB/sensor manifold, see **Figure 8**.
- Insert, the new sensor assembly and replace sensor manifold and 2 retaining screws.
- Replace, lid and the 4 retaining screws.
- Re-supply power to the **CO-GUARD**

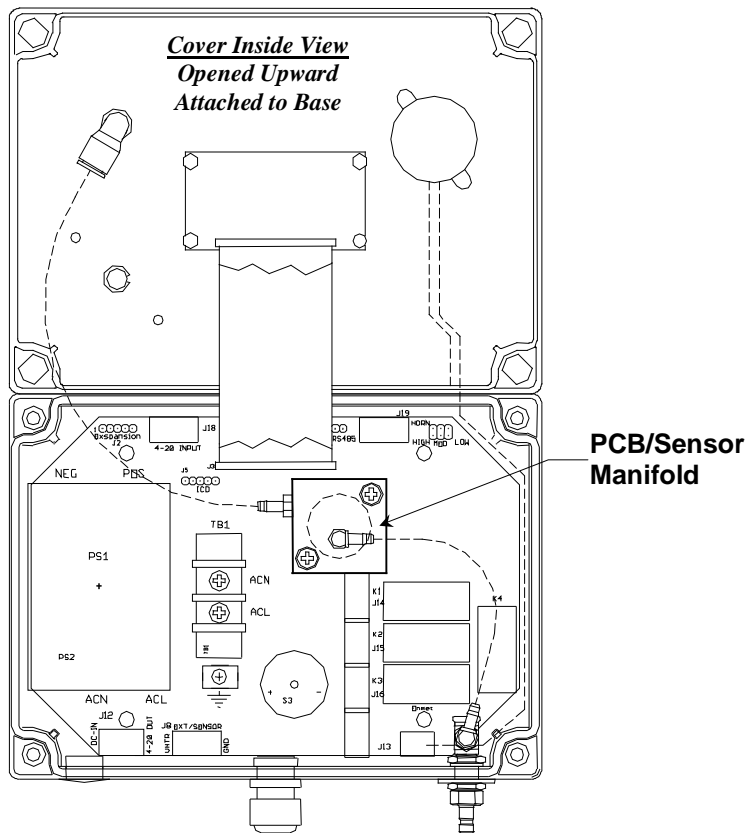

Figure 8: CO-GUARD Sensor Replacement

After the new sensor assembly has been installed, it is suggested to allow the sensor to stabilize for 3 – 4 hours.

A Factory calibration must be performed.

After entering the Maintenance menu, press and hold the **MENU** button for 2-4 seconds while viewing the Zero menu.

After 2-4 seconds, an F will appear on the far right hand side of the display. The F indicates that the instrument is in Factory mode.

Perform the calibration Zero and Span procedures as outlined in **Section 5.2**. Be sure that the F is present when selecting the Zero and Span functions.

The Factory calibration sets a calibration window for future standard instrument calibrations.

6.0 Replacement Parts

ENMET replacement part numbers:

Description of Part	Part Number
Sensor CO	67025-1200
Calibration Regulator, for 17 liter, cylinder	03700-500
Calibration gas, 20ppm CO, 17 liter	03219-020
Zero Gas, 20.9% O ₂ , 17 liter	03296-209
Aerosol gas, 20ppm CO	03101-020
Aerosol gas, 20.9% O ₂	03100-209
Sampling Regulator w/hose, quick disconnect	03412-003
Sampling Hose w/quick disconnect	03412-004
Adapter aerosol cylinder	03700-036
Adapter quick disconnect mini to Pushlock	03700-038
Horn	62013-007

7.0 Technical Data and Specifications

Electrical Power	15 Amp fused branch circuit	
	100-240 VAC	
	0.45A, 50/60 Hz	
	0.6A, 24VDC	
Storage and Transport	Temperature:	-20° to +60°C (-4° to +140°F)
	<i>preferred</i>	0° to +20°C (32° to 68°F)
	Relative Humidity	10-99% RH, non-condensing
	Atmospheric Pressure	20 to 36 inHg (68 to 133 kPa)
Operation	Temperature:	0° to +40°C (32° to +104°F)
	Relative Humidity	10-99% RH, non-condensing
	Atmospheric Pressure	20 to 36 inHg (68 to 133 kPa)
Mechanical	Dimensions:	7.1 x 5.1 x 3 in(180x130x75mm)
	Weight:	2 lbs (0.9 kg)
	Material:	Polycarbonate
	Strain relief:	3-6.5mm OD, 1 supplied
Outputs	Relays:	SPDT Resistive Load Inductive Load 10A at 110 VAC 7.5A at 110 VAC 10A at 30 Vdc 5A at 30 Vdc
	Analog:	4-20mA
	Digital:	RS-485-modbus
	Audio:	105 dB at 30cm/12in

NOTE: All specifications stated in this manual may change without notice.

8.0 WARRANTY

ENMET warrants new instruments to be free from defects in workmanship and material under normal use for a period of one year from date of shipment from **ENMET**. The warranty covers both parts and labor excluding instrument calibration and expendable parts such as calibration gas, filters, batteries, etc... Equipment believed to be defective should be returned to **ENMET** within the warranty period (transportation prepaid) for inspection. If the evaluation by **ENMET** confirms that the product is defective, it will be repaired or replaced at no charge, within the stated limitations, and returned prepaid to any location in the United States by the most economical means, e.g. Surface UPS/FedEx Ground. If an expedient means of transportation is requested during the warranty period, the customer is responsible for the difference between the most economical means and the expedient mode. **ENMET** shall not be liable for any loss or damage caused by the improper use of the product. The purchaser indemnifies and saves harmless the company with respect to any loss or damages that may arise through the use by the purchaser or others of this equipment.

This warranty is expressly given in lieu of all other warranties, either expressed or implied, including that of merchantability, and all other obligations or liabilities of **ENMET** which may arise in connection with this equipment. **ENMET** neither assumes nor authorizes any representative or other person to assume for it any obligation or liability other than that which is set forth herein.

NOTE: When returning an instrument to the factory for service:

- Be sure to include paperwork.
- A purchase order, return address and telephone number will assist in the expedient repair and return of your unit.
- Include any specific instructions.
- For warranty service, include date of purchase
- If you require an estimate, please contact **ENMET** Corporation.

There are Return for Repair Instructions and Form on the last pages of this manual. This Form can be copied or used as needed.

Manual Part Number
80002-044

April 2006
MCN-347, 05/18/06
MCN-355, 01/08/07
MCN-373, 06/20/07
MCN-381, 10/17/07

Notes:



PO Box 979
680 Fairfield Court
Ann Arbor, Michigan 48106-0979
734.761.1270 Fax 734.761.3220

Returning an Instrument for Repair

ENMET instruments may be returned to the factory or any one of our Field Service Centers for regular repair service or calibration. The **ENMET** Repair Department and Field Service Centers also perform warranty service work.

When returning an instrument to the factory or service center for service, paperwork must be included which contains the following information:

- A purchase order number or reference number.
- A contact name with return address, telephone and fax numbers
- Specific instructions regarding desired service or description of the problems being encountered.
- Date of original purchase and copy of packing slip or invoice for warranty consideration.
- If a price estimate is required, please note it accordingly *and be sure to include a fax number.*

Providing the above information assists in the expedient repair and return of your unit.

Failure to provide this information can result in processing delays.

ENMET charges a one hour minimum billing for all approved repairs with additional time billed to the closest tenth of an hour. All instruments sent to **ENMET** are subject to a minimum \$30 evaluation fee, even if returned unrepaired. Unclaimed instruments that **ENMET** has received without appropriate paperwork or attempts to advise repair costs that have been unanswered, after a period of 60 days, may be disposed of or returned unrepaired COD with the evaluation fee.

Service centers may have different rates or terms. Be sure to contact them for this information.

Repaired instruments are returned by UPS/FedEx Ground and are not insured unless otherwise specified. If expedited shipping methods or insurance is required, it must be stated in your paperwork.

Note: Warranty of customer installed components.

If a component is purchased and installed in the field, and fails within the warranty term, it can be returned to **ENMET** and will be replaced, free of charge, per **ENMET's** returned goods procedure.

If the entire instrument is returned to **ENMET** Corporation with the defective item installed, the item will be replaced at no cost, but the instrument will be subject to labor charges at half of the standard rate.

