



## Oilless Reciprocating Air Compressor Pumps

Please read and save these instructions. Read carefully before attempting to assemble, install, operate or maintain the product described. Protect yourself and others by observing all safety information. Failure to comply with instructions could result in personal injury and/or property damage! Retain instructions for future reference.

### Descriptions

#### GENERAL

Powerex utilizes cutting-edge compressor technology to provide the most advanced oilless reciprocating air compressor in the industry. The Powerex reciprocating compressor is available in single and two stage models. Continuously lubricated, sealed bearings provide oil-free compressed air and long compressor life. The onboard fan, finned flywheel and temperature reducing composite piston create lower operating temperatures.

#### DRY TYPE INLET FILTER

The inlet filter on the oilless compressor assures 99% of particulate free air, down to 10 micron, is admitted to the unit. Change every 2500 hours or more often in dirty locations (See Figure 5).

#### PISTON AND PISTON RINGS

The Powerex oilless reciprocating compressor pistons are made of a high-strength, self-lubricating composite using the most advanced technology available. These heat reducing pistons eliminate the effect of excessive grease leakage at the wrist pin bearing.

Teflon® rings reduce wear and provide self lubrication. Piston rings should be replaced every 10,000 hours of operation (See Figure 6).

#### BEARING REGREASE

The wrist pin bearings of the OPS and OPT oilless compressors are needle bearings protected by two outer lip seals. This needle bearing becomes impacted and requires regreasing at 5,000 hours (See Figure 6).

### Installation

#### INSTALLATION SITE

1. The oilless compressor must be located in a clean, well lit and well ventilated area.
2. The area should be free of excessive dust, toxic or flammable gases and moisture.
3. Never install the compressor where the ambient temperature is higher than 105° F or where humidity is high.
4. Clearance must allow for safe, effective inspection and maintenance.

#### Minimum Clearances

Above	24"
Drive belt side	12"
Other sides	20"

### **⚠ DANGER**

#### Breathable Air Warning

This compressor/pump is NOT equipped and should NOT be used "as is" to supply breathing quality air. For any application of air for human consumption, you must fit the compressor/pump with suitable in-line safety and alarm equipment. This additional equipment is necessary to properly filter and purify the air to meet minimal specifications for Grade D breathing as described in Compressed Gas Association Commodity Specification G 7.1 - 1966, OSHA 29 CFR 1910. 134, and/or Canadian Standards Associations (CSA).

#### DISCLAIMER OF WARRANTIES

In the event the compressor/pump is used for the purpose of breathing air application and proper in-line safety and alarm equipment is not simultaneously used, existing warranties are void, and Powerex disclaims any liability whatsoever for any loss, personal injury or damage.

### Specifications

Model	HP	Max. PSIG	SCFM @ 100 PSIG	RPM	No. of Cyl.	Bore	Stroke	Flywheel O.D.	Drive	Weight (lbs.)
OPS 010	1	125	3.6	620	1	2.7	2.7	11.0	1 GR-A	34
	1.5		5.3	980						
OPS 030	2	125	6.5	680	2	2.7	2.4	13.8	1 GR-B	65
	3		10.1	970						
OPT050	5	150	16.7	870	2	4.31 x 3.1	3.5	16.9	2 GR-B	95
OPT 100	7.5	150	26.1	840	3	3.7 x 3.1	3.5	18.3	2 GR-B	134
	10		35.0	1070						
OPT 150	15	150	54.2	1250	3	4.31 x 3.1	3.5	19.7	2 GR-B	137

# Oilless Reciprocating Air Compressor Pumps

---

5. If necessary, use metal shims or leveling pads to level the compressor. Never use wood to shim the compressor.

## VENTILATION

1. If the oilless compressor is located in a totally enclosed room, an exhaust fan with access to outside air must be installed.
2. Never restrict the cooling fan exhaust air.
3. Never locate the compressor where hot exhaust air from other heat generating units may be pulled into the unit.

## WIRING

Refer to the general safety guidelines manual. All electrical hook-ups must be performed by a qualified electrician. Installations must be in accordance with local and national electrical codes. Use solderless terminals to connect the electric power source.

## PIPING

Refer to the general safety guidelines manual.

1. Make sure the piping is lined up without being strained or twisted when assembling the piping for the compressor.
2. Appropriate expansion loops or bends should be installed at the compressor to avoid stresses caused by changes in hot and cold conditions.
3. Piping supports should be anchored separately from the compressor to reduce noise and vibration.
4. Never use any piping smaller than the compressor connection.
5. Use flexible hose to connect the outlet of the compressor to the piping so that the vibration of the compressor does not transfer to the piping. Make sure the flexible hose is rated for proper pressure and temperature before installing.

## SAFETY VALVES

Tank mounted compressors are shipped from the factory with safety valves installed in the tank manifold. The flow capacity of the safety valve is equal to

or greater than the capacity of the compressor.

1. The pressure setting of the safety valve must be no higher than the maximum working pressure of the tank.
2. Safety valves should be placed ahead of any possible blockage point in the system, i.e. shutoff valve.
3. Avoid connecting the safety valve with any tubing or piping.
4. Manually operate the safety valve every six months to avoid sticking or freezing.

## HOURMETER

The hourmeter on the oilless compressor indicates the actual number of hours the unit has been in operation. The hourmeter is also used to determine maintenance and service timing.

**An hourmeter must be installed with every oilless compressor.**

## CONDENSATE DRAIN VALVE

A condensate drain valve must be installed on any tank to allow removal of the liquid which will collect during compressor operation.

### NOTICE

*Drain liquid from tank daily.*

## Operation

Powerex oilless single stage compressors operate at a maximum pressure of 125 PSIG. Two stage compressors operate at a maximum of 150 PSIG and are equipped for continuous duty. Compressor RPM's are established by Powerex based on horsepower and operating pressure.

## BEFORE START UP

1. Make sure all safety warnings, labels and instructions have been read and understood before continuing.
2. Remove any shipping materials, brackets, etc.
3. Confirm that the electric power source and ground have been firmly connected.

4. Be sure all pressure connections are tight.
5. Check to be certain all safety relief valves, etc., are correctly installed.
6. Check that all fuses, circuit breakers, etc., are the proper size.
7. Make sure the inlet filter is properly installed.
8. Confirm that the drain valve is closed.
9. Visually check the rotation of the compressor pump. If the rotation is incorrect, have a qualified electrician correct the motor wiring.

## START-UP AND OPERATION

1. Follow all the procedures under "Before start-up" before attempting operation of the compressor.
2. Switch the electric source breaker on.
3. Open the tank discharge valve completely.
4. Check that the compressor operates without excessive vibration, unusual noises or leaks.
5. Close the discharge valve completely.
6. Check the discharge pressure. Also make sure the air pressure rises to the designated pressure setting by checking the discharge pressure gauge.
7. Check the operation of the pressure switch or the pilot valve for continuous run units by opening the stop valve and confirming the compressor starts or reloads as pressure drops.

Switch the breaker OFF if the compressor is not to be used for a long period of time.

### NOTICE

*These units are equipped with head unloaders for continuous operation.*

# Oilless Reciprocating Air Compressor Pumps

## Dimensions (inches)

Model No.	HP	A	B	C	D	E	F	G (Diameter)	H (O.D. Flywheel)
OPS 010	1 - 1½	6.7	3.2	11.9	16.2	11.0	4.3	.38	Ø11.0 Ax1
OPS 030	2 - 3	8.3	3.7	13.4	17.8	18.9	6.0	.43	Ø13.8 Bx1
OPT 050	5	11.4	5.3	18.0	21.8	26.0	7.6	.43	Ø16.9 Bx2
OPT 100	7½ - 10	12.2	6.3	20.0	21.7	29.7	8.0	.55	Ø18.3 Bx2
OPT 150	15	12.2	6.3	20.0	21.7	29.7	8.0	.55	Ø19.7 Bx2

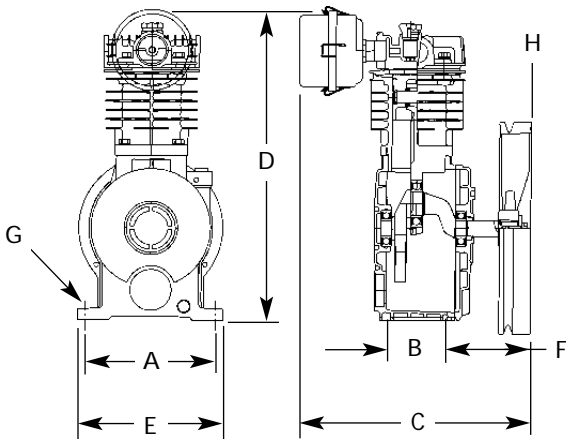

Figure 1 - Model OPS 010

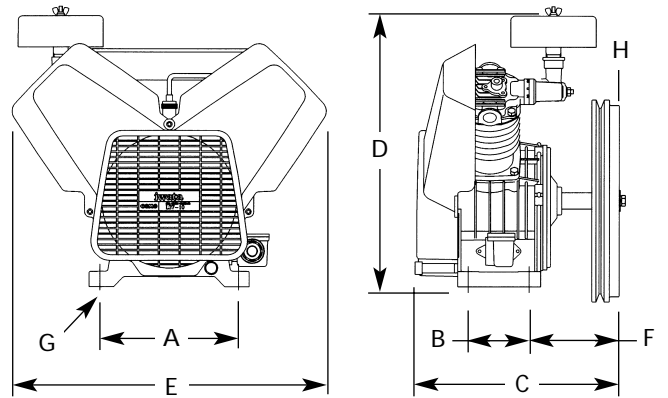

Figure 2 - Model OPS 030

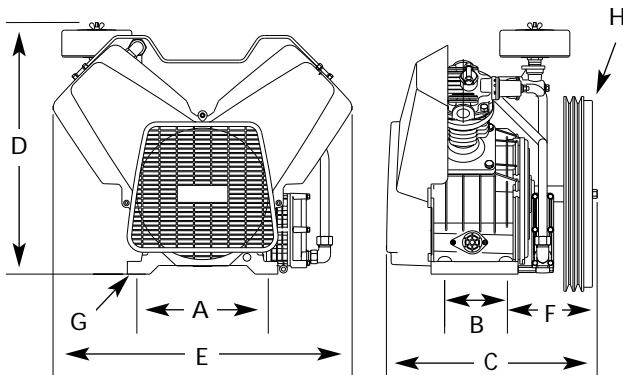

Figure 3 - Model OPT050

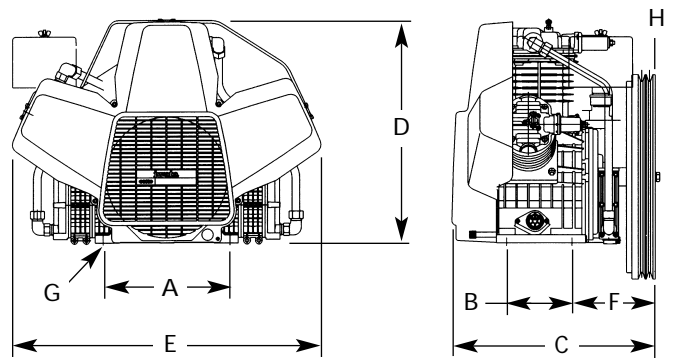

Figure 4 - Models OPT 100 and OPT 150

# Oilless Reciprocating Air Compressor Pumps

## Maintenance Schedule

Item	Action needed	Operating Hours				Remarks		
		500	2500	5000	10,000		15,000	20,000
Tank	Drain moisture	Daily					Drain tank daily	
Inlet air Filter	Replace	●	▲	(Every 2,500 hrs or less)				
Blower Fan	Clean			●	●	●	●	
Fan Duct	Clean			●	●	●	●	
Compressor Fins	Clean		●	(Every 2,500 hrs or less)				
Bearings	Replace				●	●	▲	
Compression Rings	Replace			●	▲	●	▲	
Wrist pin Bearing	Regrease			▲	▲	▲	▲	
Piston Set	Inspect				▲		▲	
V-belt	Inspect, replace	*Note 3	●	▲	▲	▲	▲	
Pressure Switch	Confirm operation				●		●	
Magnetic Starter	Inspect				●		●	Replace if contact points deteriorated
Safety Valve	Confirm operation		●	(Every 2,500 hrs or less)				
Pressure Gauge	Inspect		●	(Every 2,500 hrs or less)				
●	Inspect							
▲	Replace							

### NOTES:

1. Inspect and perform maintenance periodically according to maintenance schedule.
2. The maintenance schedule relates to the normal operating conditions. If the circumstances and load condition are adverse, shorten the cycle time and do maintenance accordingly.
3. \* The tension of the V-belt should be adjusted during the initial stage and inspected every 1,500 hours afterwards. Proper belt tension for 1 to 3 HP units is 2-3 lbs./1.5" deflection; for 5 to 15 HP units, 4-6 lbs./1.5" deflection.

## Air Filter Replacement

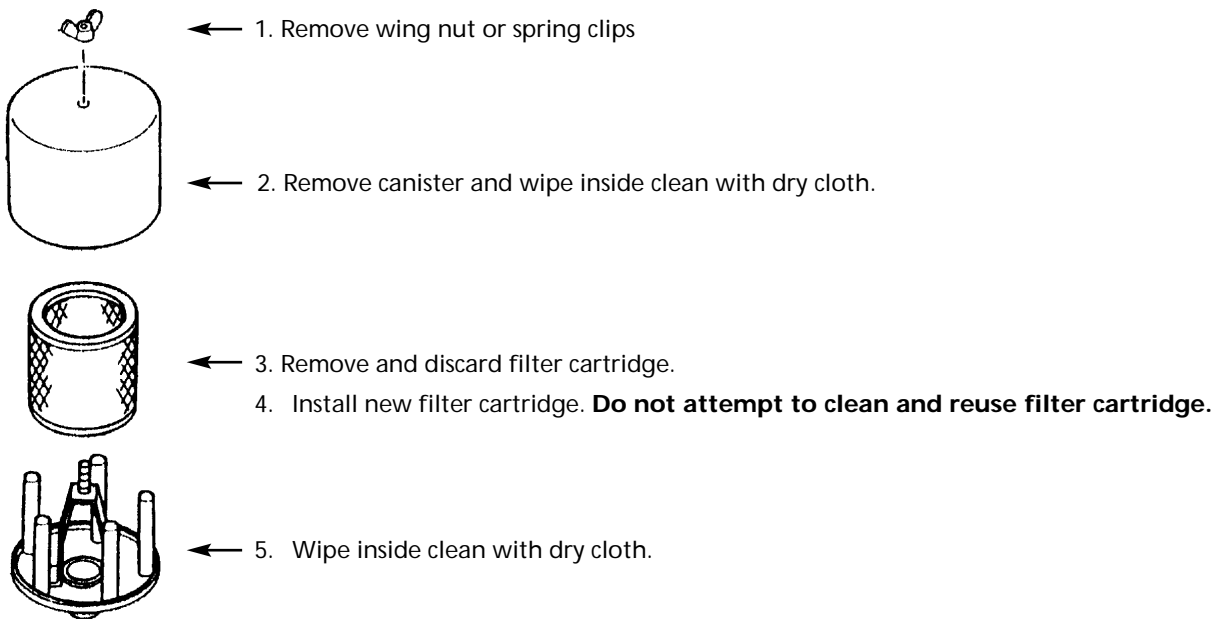
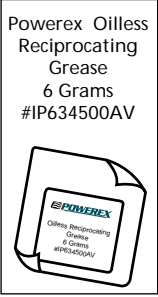
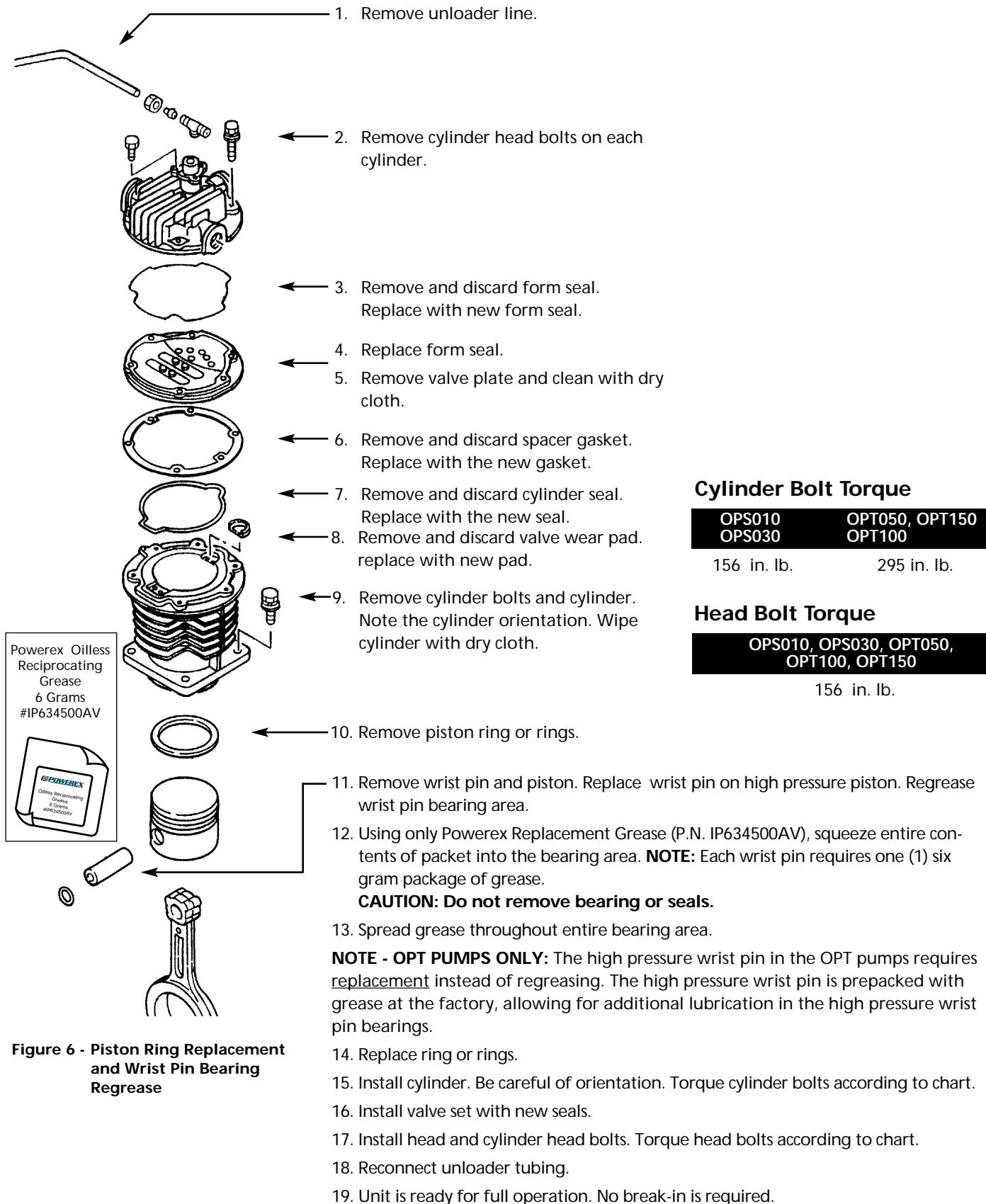

Figure 5 - Air Filter Replacement

# Oilless Reciprocating Air Compressor Pumps

## Piston Ring Replacement 10,000 Hours • Wrist Pin Bearing Regrease 5,000 Hours



### Cylinder Bolt Torque

OPS010	OPT050, OPT150
OPS030	OPT100
156 in. lb.	295 in. lb.

### Head Bolt Torque

OPS010, OPS030, OPT050, OPT100, OPT150
156 in. lb.

**Figure 6 - Piston Ring Replacement and Wrist Pin Bearing Regrease**



## Oilless Reciprocating Air Compressor Pumps

Ref. No.	Description	Part Number for model OPS010	Qty
1	Cylinder	91000560	1
6	Cylinder head	91002630	1
16	Elbow (Unloader)	06800261	1
18	Unloader cap	01052041	1
24	Spring guide set	91932560	1
27	Bolt (cylinder head)	06137835	4
33	Bolt (cylinder)	06137825	8
34	Bolt (bearing cap)	06137620	8
35	Crankcase	91100630	1
36	Bearing cap	91101630	1
47	O-ring	01146550	1
50	Crank shaft	▲	1
51	Flywheel pulley	91201551	1
52	Parallel pin	01271550	1
57	Ball bearing (bearing cap)	▲	2
62	Hex blot (fan, flywheel)	06992857	1
65	Connecting rod w/bearings	▲	1
67	Piston set	91903640	1
67-1	Piston ring	91237640	1
72	Intake filter set	91906630	1
72-1	Intake filter	91348550	1
84	Screw (dust cover)	06131508	2
99	Seat (intake valve)	01301560	1
121	Dust cover	91383630	1
200	Unloader set	91931560	1
500	Gasket set	91936640	1
600	Valve set with gasket	91933640	1
▲	Crank shaft set (Includes 50, 57 and 65)	91918630	1





## Oilless Reciprocating Air Compressor Pumps

Ref. No.	Description	Part Number for model OPS030	Qty
1	Cylinder	91000560	2
6	Cylinder head	91002640	2
16	Elbow (unloader)	06800261	1
17	Tee union assembly	06803261	1
20	Intake joint (1)	91345561	1
21	Intake joint (2)	91346571	1
24	Spring guide set	91932560	2
27	Bolt (cylinder head)	06137835	8
30	Flange (breather)	91176660	1
31	Bolt	06995831	20
33	Bolt (cylinder)	06137825	8
34	Bolt (bearing cap)	06137620	8
35	Crank case	91100640	1
36	Bearing cap	91101560	1
38	Filter (crank case)	91348690	1
47	O-ring	01146560	1
50	Crank shaft	▲	1
51	Flywheel pulley	91202560	1
52	Woodruff key	06600013	1
53	Hex nut	06994016	2
57	Ball bearing (bearing cap)	▲	1
58	Ball bearing (crank case)	▲	1
59	Fan	91220560	1
60	Cover (fan)	91134560	1
61	Hex bolt (fan, flywheel)	06992857	2
64	Liner (connecting rod)	01480640	1
65	Connecting rod w/bearing	▲	2
67	Piston set	91903640	2
67-1	Piston ring	91237640	2
72	Intake filter set	91907570	1
72-1	Intake filter	91353660	1
78	O ring	06630032	2
79	Intake pipe	91407560	1
82	Screw (filter)	06131508	2
87	Tube	01909400	1
99	Seat (intake valve)	01301560	2
109	O ring (intake joint)	06639906	2
193	Fan guard	91135560	2
195	Bolt (intake joint 1)	01095570	1
196	Bolt (intake joint 2)	01095560	1
200	Unloader set	91931560	2
500	Gasket set	91936640	2
600	Valve set with gasket	91933640	2
▲	Crankshaft set (includes part #'s 50, 57, 58 and 65)	91918640	1

# Oilless Reciprocating Air Compressor Pumps

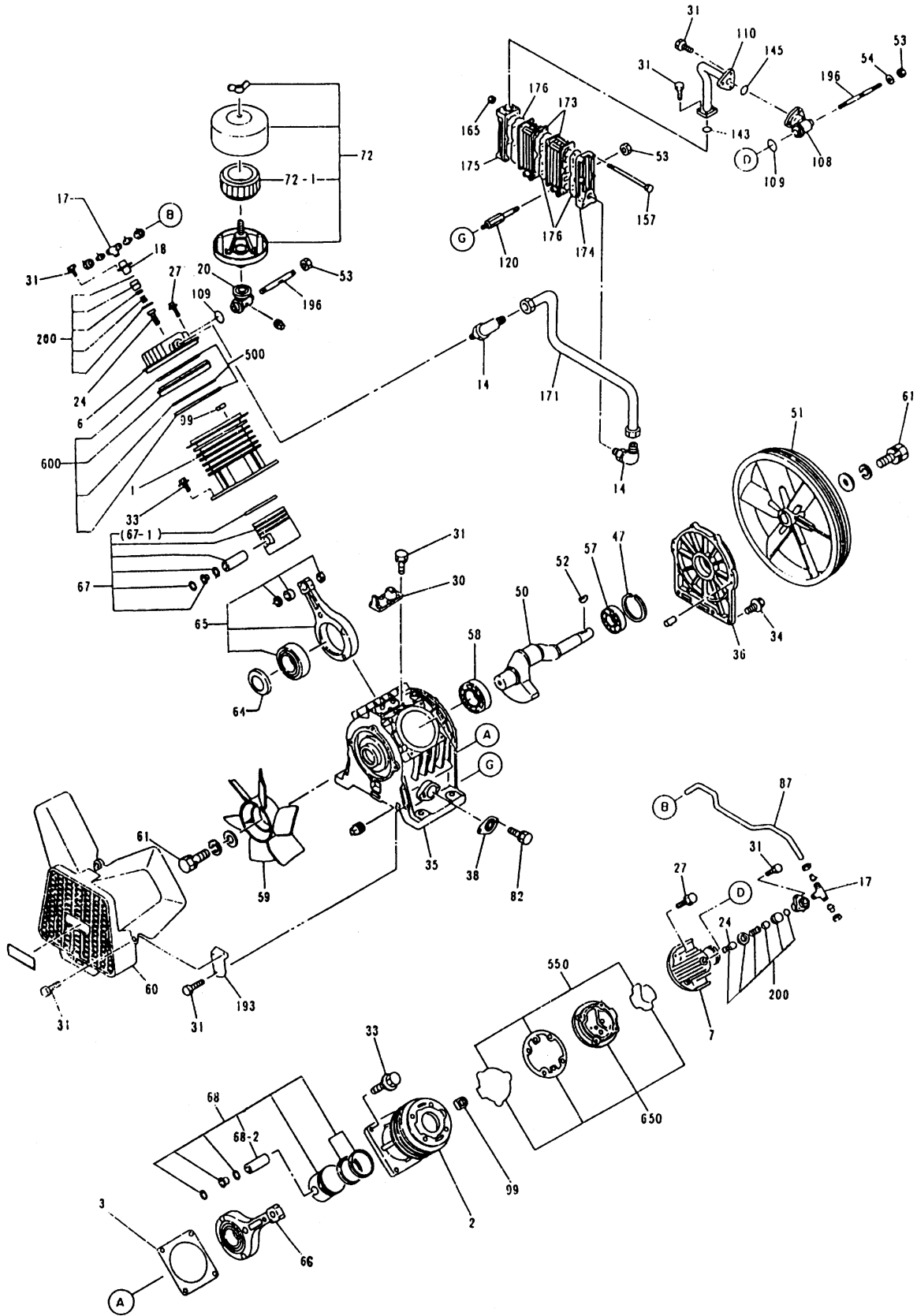

Figure 9 - Replacement Parts Illustration for OPT050

## Oilless Reciprocating Air Compressor Pumps

Ref. No.	Description	Part Number for model OPT050	Qty	Ref. No.	Description	Part Number for model OPT050	Qty
1	Cylinder (LP)	91000680	1	145	O-Ring (Connecting Pipe)	06632835	1
2	Cylinder (HP)	91001680	1	157	Hex. Bolt (Intercooler)	06996460	6
3	Liner	91177680	2	165	Nut (Intercooler)	06994015	6
6	Cylinder Head (LP)	91002691	1	171	Connecting Pipe Set	91914661	1
7	Cylinder Head (HP)	91002680	1	173	Intercooler	91404690	2
14	Elbow (Intercooler)	01415690	2	174	Intercooler Flange (1)	91405690	1
17	Tee Union Ass'y	06803261	2	175	Intercooler Flange (2)	91406690	1
18	Unloader Cap	01052451	2	176	Gasket (Intercooler)	01432690	3
20	Intake Joint	91345660	1	193	Fan Guard	91144660	2
24	Spring Guide Set	91949694	2	196	Bolt (Intake Joint)	01344690	2
27	Bolt (Cylinder Head)	06137850	10	200	Unloader Set	91932681	2
30	Flange (Breather)	91176660	1	500	Gasket Set (LP)	91936680	1
31	Bolt (Unloader Cap)	06995831	26	550	Gasket Set (HP)	91937681	1
33	Bolt (Cylinder)	06137130	8	600	Valve Set with Gasket (LP)	91933681	1
34	Bolt (Bearing Cap)	06137830	10	650	Valve Set with Gasket (HP)	91934683	1
35	Crank Case	91100660	1	▲	Crank Shaft Set (50, 57, 58, 65, 66)	91918660	1
36	Bearing Cap	91101580	1				
38	Filter (Crank Case)	91348690	1				
47	O-ring	01146430	1				
50	Crank Shaft	▲	1				
51	Flywheel Pulley	91201660	1				
52	Woodruff Key	06600016	1				
53	Hex Nut	06994016	4				
54	Washer	06991512	1				
57	Ball Bearing (Brg. Cap)	▲	1				
58	Ball Bearing (Crank Case)	▲	1				
59	Fan	91220690	1				
60	Cover (Fan)	91134660	1				
61	"Hex Bolt (Fan , Flywheel)"	06992817	2				
64	Liner (Connectng Rod)	91472690	1				
65	Connecting Rod Set	▲	1				
66	Connecting Rod Set	▲	1				
67	Piston Set (LP)	91903680	1				
67-1	Piston Ring	91236681	1				
68	Piston Set (HP)	91904680	1				
68-1	Piston Ring	91237681	2				
68-2	Wrist Pin (Prepacked)	91924680	1				
72	Intake Filter Set	91907660	1				
72-1	Intake Filter	91353660	1				
82	Screw (Filter)	06235304	2				
87	Unloader Tube	91420660	1				
99	Seat (Intake Valve)	01301691	2				
108	Intercooler Flange	91403690	1				
109	O Ring (Intake joint)	06639906	2				
110	Connecting Pipe	91400660	1				
120	Bolt (Intercooler)	01435692	2				
143	O-Ring (Connecting Pipe)	06632825	1				

# Oilless Reciprocating Air Compressor Pumps

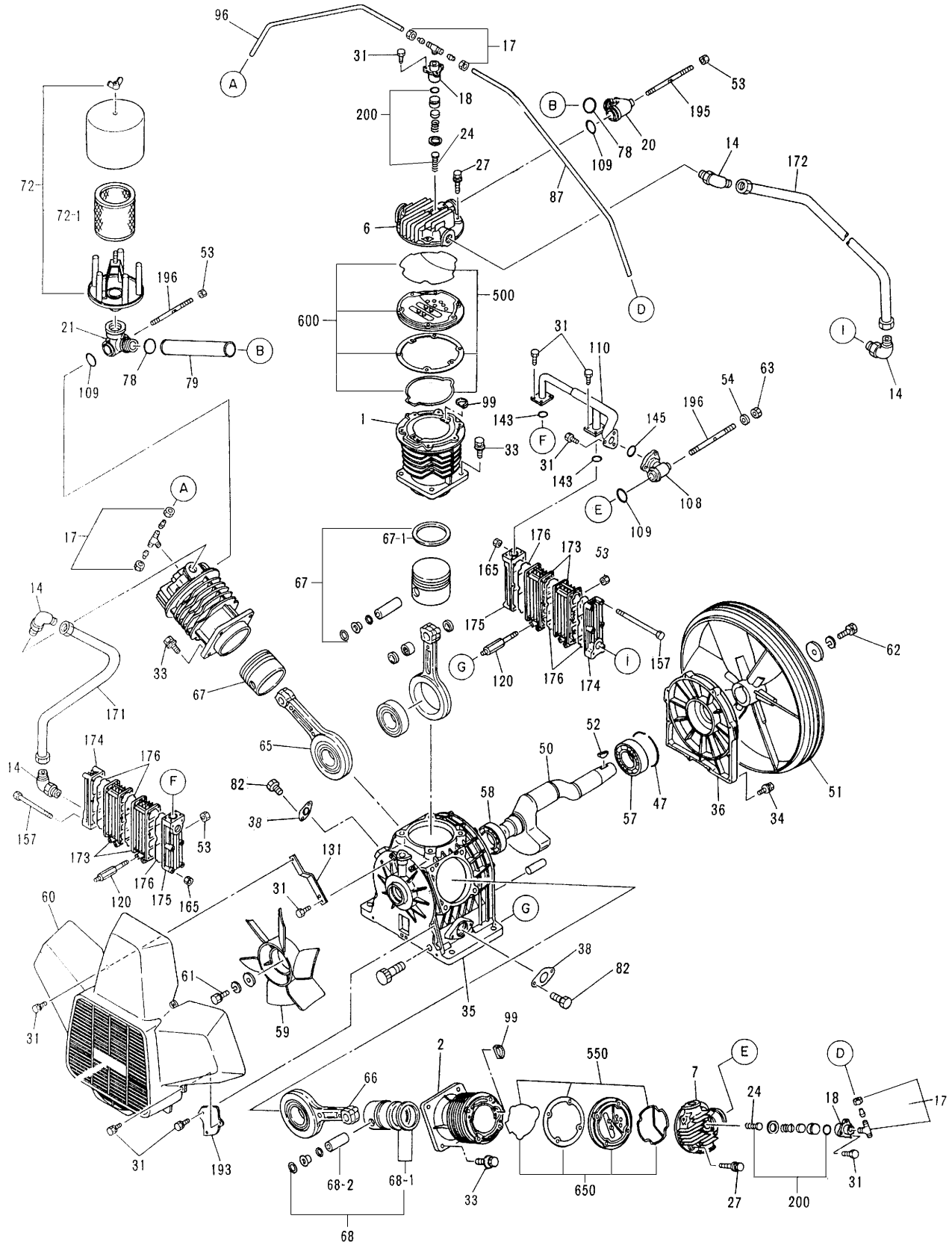

Figure 10 - Replacement Parts Illustration for OPT100 and OPT150

## Oilless Reciprocating Air Compressor Pumps

Ref. No.	Description	Part Numbers For Models		Qty
		OPT100	OPT150	
1	Cylinder (LP)	91000670	91000680	2
2	Cylinder (HP)	91001680	91001680	1
6	Cylinder head (LP)	91002691	91002691	2
7	Cylinder head (HP)	91002680	91002680	1
14	Elbow (Intercooler)	01415690	01415690	4
17	Tee union assembly	06803261	06803261	3
18	Unloader cap	01052451	01052451	3
20	Intake joint (1)	01345691	01345691	1
21	Intake joint (2)	01346690	01346690	1
24	Spring guide set	91949694	91949694	3
27	Bolt (Cylinder head)	06137850	06137850	16
31	Bolt (Unloader cap)	06995831	06995831	30
33	Bolt (Cylinder)	06137130	06137130	12
34	Bolt (Bearing cap)	06137830	06137830	10
35	Crank case	91100680	91100680	1
36	Bearing cap	91101690	91101690	1
38	Filter (Crank case)	91348690	91348690	1
47	O-ring (Bearing cap)	01146690	01146690	1
50	Crank shaft	▲	▲	1
51	Flywheel pulley	01201590	91201690	1
52	Woodruff key	06600016	06600016	1
53	Hex nut	06994016	06994016	6
54	Washer (Intercooler)	06991512	06991512	1
57	Ball bearing (Bearing cap)	▲	▲	1
58	Ball bearing (Crank case)	▲	▲	1
59	Fan	91220690	91220690	1
60	Fan cover	91134690	91134690	1
61	Hexagon bolt (Fan)	06992817	06992817	1
62	Hexagon bolt (Flywheel)	06992833	06992833	1
63	Hexagon nut (Intake joint)	06382086	06382086	1
65	Connecting rod (LP)	▲	▲	2
66	Connecting rod (HP)	▲	▲	1
67	Piston set (LP)	91903670	91903680	2
67-1	Piston ring (LP)	91236671	91236681	2
68	Piston set (HP)	91904680	91904680	1
68-1	Piston ring (HP)	91237681	91237681	2
68-2	Wrist pin set (prepacked)	91924680	91924680	1
72	Intake filter set	91907590	91907690	1
72-1	Intake filter	91353690	91353690	1
78	O-ring (Intake pipe)	06630032	06630032	2
79	Inlet pipe	01407690	01407690	1
82	Bolt (Crankcase filter)	06131508	06131508	4
87	Unloader tube	01420690	01420690	1
96	Unloader tube	01419600	01419600	1
99	Wear pad, valve	01301691	01301691	3
108	Intercooler Joint	91403690	91403690	1
109	O Ring ( Intercooler Joint )	06639906	06639906	3
110	Connecting Pipe	91402680	91402680	1
120	Bolt ( Intercooler )	01435692	01435692	4
131	Cover Bracket	01413690	01413690	2
143	O Ring ( Connecting Pipe )	06632825	06632825	2
145	O Ring ( Connecting Pipe )	06632835	06632835	1
157	Hex bolt ( Intercooler )	06996460	06996460	6
165	Nut ( Intercooler )	06994015	06994015	6
171	Connecting Pipe Set ( 1 )	01914590	01914690	1
172	Connecting Pipe Set ( 2 )	01915590	01915690	1
173	Intercooler	91404690	91404690	4
174	Intercooler Flange ( 1 )	91405690	91405690	2
175	Intercooler Flange ( 2 )	91406690	91406690	2
176	Gasket ( Intercooler )	01432690	01432690	6
193	Fan Guard	01135690	01135690	2
195	Bolt ( Intake Joint 1 )	01343690	01343690	1
196	Bolt ( Intake Joint 2 )	01344690	01344690	2
200	Unloader Set	91932681	91932681	3
500	Gasket Set ( LP )	91936670	91936680	2
550	Gasket Set ( HP )	91937681	91937681	1
600	Valve Set with Gasket ( LP )	91934691	91933681	2
650	Valve Set with Gasket ( HP )	91934683	91934683	1
▲	Crank shaft set (Includes 50, 57, 58, 65 & 66)	91917680	91917680	1





## Oilless Reciprocating Air Compressor Pumps

---

### Powerex Limited Warranty

**Powerex 3 Year / 10,000 Hour Extended Parts Limited Warranty** - Powerex warrants each Compressor Pump or Scroll Air-End against defects in material or workmanship from the date of purchase for a period of **Three years or 10,000 hours**, whichever may occur first. This warranty applies to the exchange of part(s) of the compressor pump or air-end found to be defective by an Authorized Powerex Service Center.

**Powerex 1 Year / 5,000 Hour Inlet to Outlet Limited Warranty** - Powerex warrants each Compressor Unit, System, Pump, or Air-End against defects in material or workmanship from the date of purchase for a period of **One Year or 5,000 Hours**, whichever may occur first. This warranty applies to the exchange of defective component part(s) and labor performed by an Authorized Powerex Service Center.

The above mentioned warranty applies to POWEREX manufactured units or systems only.

Items listed in the operator's manual under routine maintenance are not covered by this or any other warranty.

THERE IS NO OTHER EXPRESS WARRANTY. IMPLIED WARRANTIES, INCLUDING THOSE OF MERCHANTABILITY AND FITNESS FOR A PARTICULAR PURPOSE, ARE LIMITED TO ONE YEAR FROM THE DATE OF PURCHASE: AND TO THE EXTENT PERMITTED BY LAW, ANY AND ALL IMPLIED WARRANTIES ARE EXCLUDED. THIS IS THE EXCLUSIVE REMEDY AND LIABILITY FOR CONSEQUENTIAL DAMAGES UNDER ANY AND ALL WARRANTIES IS EXCLUDED TO THE EXTENT EXCLUSION IS PERMITTED BY LAW.

All claims pertaining to the merchandise in this schedule, with the exception of warranty claims, must be filed with POWEREX within 6 months of the invoice date, or they will not be honored. Prices, discounts and terms are subject to change without notice or as stipulated in specific product quotations. All agreements are contingent upon strikes, accidents, or other causes beyond our control. All shipments are carefully inspected and counted before leaving the factory. Please inspect carefully any receipt of merchandise noting any discrepancy or damage on the carrier's freight bill at the time of delivery. Discrepancies or damage which obviously occurred in transit are the carrier's responsibility and related claims should be made promptly directly to the carrier. Returned merchandise will not be accepted without prior written authorization by POWEREX and deductions from invoices for shortage or damage claims will not be allowed.

**UNLESS OTHERWISE AGREED TO IN WRITING, THESE TERMS AND CONDITIONS WILL CONTROL IN ANY TRANSACTION WITH POWEREX** any different or conflicting terms as may appear on any order form now or later submitted by the buyer. All orders are subject to acceptance by POWEREX.